



claims START

0800 587 58 58



claims START is a 24 hour service for reporting all new motor insurance claims. It has been designed to simplify and shorten the claims process with the aim of getting your vehicle back on the road as soon as possible.

Whether your claim relates to a road accident, a damaged windscreen, vandalism or theft, an immediate call to claims START will ensure that where policy cover applies, your claim is handled quickly and smoothly.

We will ensure that your broker is advised and is provided with full information about the claim, and is kept up to date with its progress.

In the event of an accident, you should obtain the name, address and telephone number of:

- Any other driver(s) involved, and their vehicle registration number(s);
- Any other person(s) involved;
- Any witnesses.

Phone claims START on 0800 587 58 58 as soon as possible with details of the accident.

claims START provides the following services:

- The first point of call to notify all motor claims;
- Experienced claims advisers at the end of the telephone 24 hours a day, 365 days a year;
- No need to complete a claim form;
- Priority service and speedy repair of your vehicle at one of our nationwide award winning approved repairers.

After each new claim notification a 'Statement of Facts' will be sent to you and your broker, with confirmation of:

- The actions taken following the phone call;
- Your policy cover and excess;
- Your claim reference number;
- The address and phone number of the Allianz branch that will handle the claim to its conclusion.

After this initial notification process, the claim will be handled by our Branch staff in the usual manner.

Allianz in partnership with **AUTOGLASS** has arranged total nationwide coverage for the repair or replacement of windscreens, bodyglass and rear windows for all of your vehicles

Allianz  **AUTOGLASS**

 **claims START Card**

24 hour helpline for new motor accident and theft claims

Call free any time **0800 587 58 58**

Account _____

Policy no. _____

Limit _____ Glass Excess _____ Expiry _____

claims START

New claims: **0800 587 5858**

Legal Helpline: **0870 241 4140**
(or 0141 221 8878 in Scotland).
Master number 34881

Driver's signature or
Registration number: _____

Conditions of issue and use of this card
This card provides details of your Windscreen, Side and Rear glass cover and is valid until the stated expiry date. Where this cover applies Autoglass® will invoice Allianz Insurance direct. Any VAT or excess, where applicable, is payable direct to Autoglass®.

Where you have comprehensive insurance we will advise **AUTOGLASS**, who will produce fleet account cards specifically for you. Your driver is then able to simply present this card to the windscreen installer and the insured value will be invoiced to Allianz. The excess and VAT (if applicable) will be invoiced to you for payment.

If your insurance policy does not include glass cover or a large windscreen excess applies, **AUTOGLASS** can contact you to arrange account facilities and provide similar discounts to those customers provided with fleet account cards.

A GUIDE TO THE M.O.T. WINDSCREEN REGULATIONS

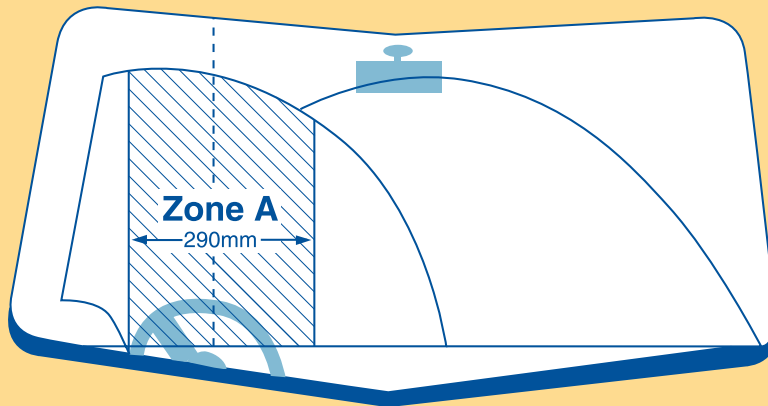

- Your vehicle will **fail** the M.O.T. if it has windscreen damage in **Zone A** which cannot be contained within a circle of 10mm diameter, or if there is a combination of minor damage areas which seriously restricts the driver's view.
- It will also **fail** if there is damage in the remainder of the area swept by the wipers which cannot be contained within a circle of 40mm.

FREE WINDSCREEN REPAIRS

Working in partnership with **Autoglass**, Allianz offer a free windscreen chip repair service to keep you safe on the road. If you have a chip smaller than a £1 coin, **Autoglass** can usually carry out a specialist repair at a time and location of your choice in just 30 minutes. But it's important to act quickly! If left untreated, the chip can turn into a crack at anytime, resulting in an expensive and time-consuming replacement for your company.